

# The HP Rack

Each unit is constructed of 2" x 2" (.25" wall) ASTM square structural and mechanical tubing

- The HP is 36"(91.4 cm) or optional 42"(91.4 cm) high x 30"(76.2 cm) wide.
- Mounting Options (see detail)
  - Flange Mount   ■ In-Ground
- Choice of four finishes:
  - Hot Dipped Galvanized
  - Powder Coating (weather resistant Polyester TGIC, 6-8 mils thick) in an unlimited range of colors.
  - ASTM A314 *schedule 40* TP304 Stainless Steel, #4 Satin Finish.
  - Thermoplastic Coating (10-12 mils thick) in red, black, green, blue, gray, white, yellow and brown.

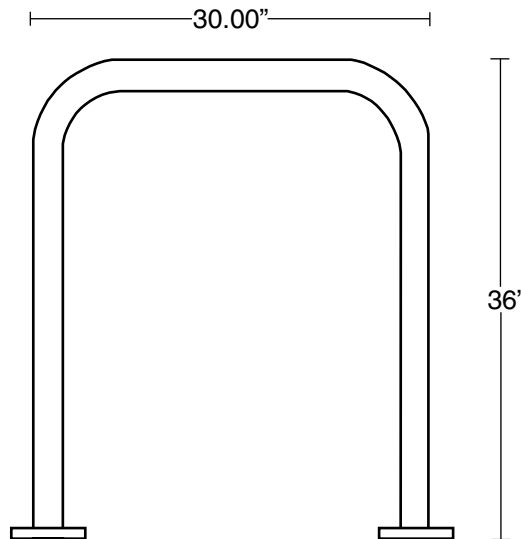
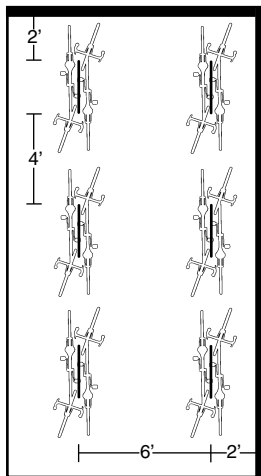
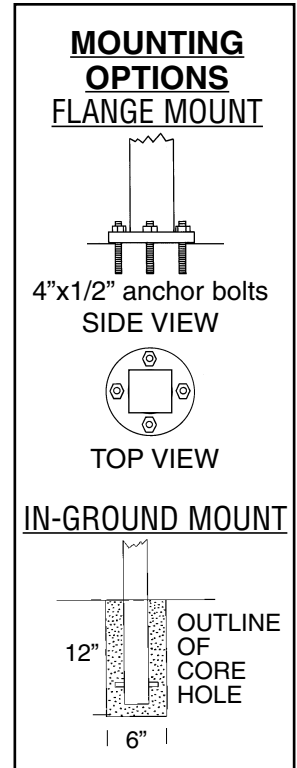

**HP 40 lbs.**