

BV-1 Bike Locker

These space-saving bike lockers are weatherproof and secure and will adapt to any venue. Each unit holds one bike.

The door handle can be locked with a standard U-shaped lock, padlock, key lock or electronic on-demand locking system. The standard, solid 14 gauge steel door, sides and roof of the locker can be perforated (as an option) for policing and ventilation.

- 14 gauge steel (door and frame) and 16 gauge steel (roof, sides) and stainless steel construction.
- Surface mount on vertically adjustable stainless steel leveling feet that insure stability
- Two finishes:
 - Single or Double Powder Coating (weather resistant Polyester TGIC, 6-8 mils thick) in an unlimited range of colors
 - Stainless Steel
- Easy assembly and disassembly for shipping
 - All hardware included
 - No exposed fasteners

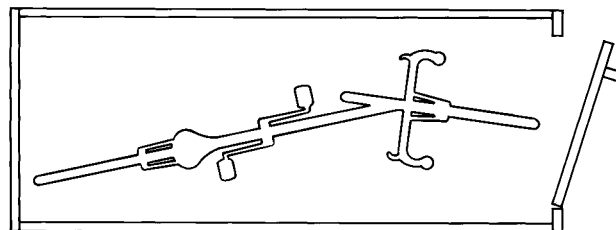
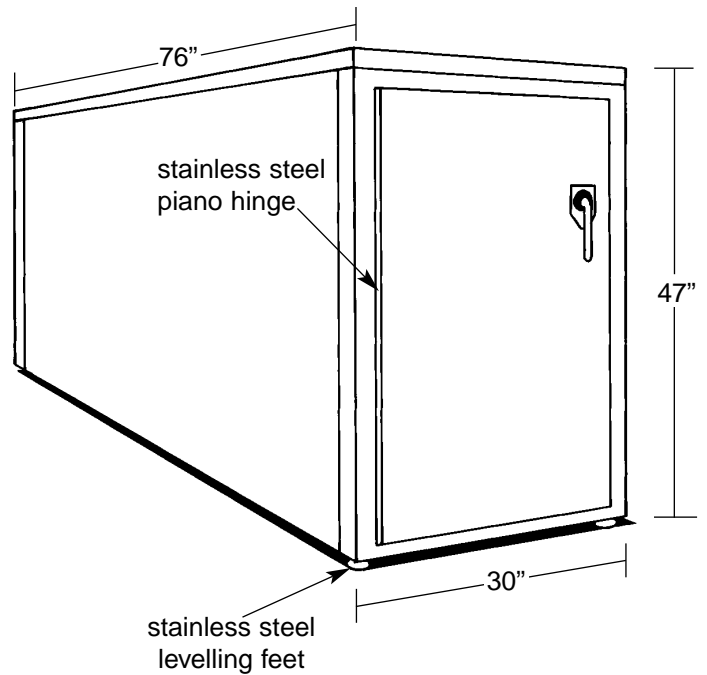
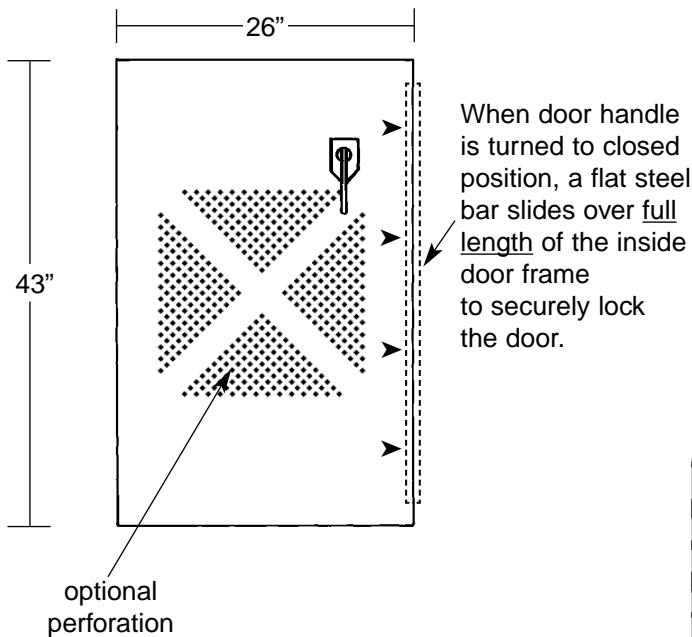

TOP VIEW